



trygonal

Backup Ring TB10/TB10G

Hydraulics/Pneumatics

Housing design

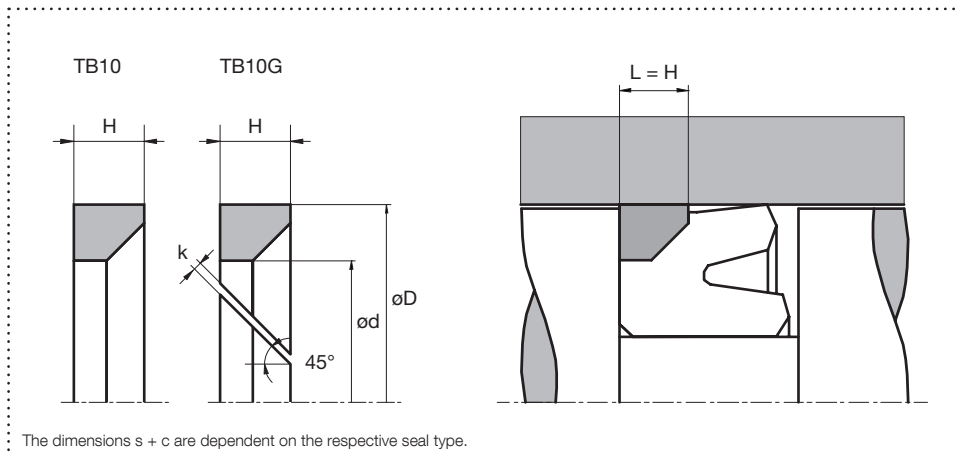

Design

- Backup ring for piston seals
- Prevents gap extrusion
- Slotted design for closed installation spaces
- Endless design possible

Application

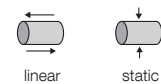

Brightened symbols:
Seal only for limited use.
Please contact us.

Surface finish

Sealing element	PU/Elastomere		PTFE		Material portion
	Roughness	Rtmax (µm)	Ra (µm)	Rtmax (µm)	
Sliding surface	≤ 2,5	0,1 – 0,5	≤ 2	0,05 – 0,3	Ratio contact area: 50 – 95% at a cutting depth of 0.5 x Rz starting from Cref = 0%
Groove base	≤ 6,3	≤ 1,6	≤ 6,3	≤ 1,6	
Groove flanks	≤ 15	≤ 3	≤ 15	≤ 3	

Standard dimensions

from nominal inside diameter $\varnothing d \geq 4,5\text{mm}$

Profile size, surface specifications and tolerances result from the combination with the respective application-specific sealing element. Standard design: cut 45°, cutting gap width 0.

Material and application parameters

Sealing element	Temperature (°C)
XHPU solid	-30 – +110
XHPU lubric	-20 – +110
POM	-50 – +100
PTFE glass wear	-200 – +260
PA6G	-40 – +100
Peek nature diet	-60 – +260

The specified application parameters are generally valid values and must not be used simultaneously with the application. An order can be placed by specifying the profile type, material and specified housing design dimensions.